

Owners Guide and Installation Instructions



Solar Loline Conversion Kit Electric Water Heater



Install a Rheem



WARNING: Plumber – Be Aware
Use copper pipe ONLY. Plastic pipe MUST NOT be used.
It is a requirement of a solar water heater installation that all pipe work be in copper and not plastic, due to the effects of high water temperatures and pressures.

*This water heater must be installed and serviced by an authorised person.
Please leave this guide with the householder.*



WARNING: Plumber – Be Aware:

- The solar cold and hot pipes between the solar storage tank and the solar collectors **MUST BE** of copper and fully insulated with Armaflex insulation or similar (minimum thickness 10 mm).
- Plastic pipe **MUST NOT** be used, as it will not withstand the temperature of the water generated by the solar collectors under stagnation conditions. The solar collectors can generate extremely high water temperatures, up to 150°C, and high water pressure of 1000 kPa. Plastic pipe cannot withstand these temperatures and pressures, and **MUST NOT** be used. Failure of plastic pipe can lead to the release of high temperature water and cause severe water damage and flooding. Refer to Warning on page 29.

PATENTS

This water heater may be protected by one or more patents or registered designs in the name of Rheem Australia Pty Ltd.

CONTENTS

HOUSEHOLDER – We recommend you read pages 4 to 17.
The other pages are intended for the installer but may be of interest.

About your water heater	4
Regular care	9
How your water heater works	10
Save a service call	14
Installation – Solar storage tank	18
Installation – Solar control unit	24
Installation – Solar collectors	27
Connections – Plumbing	28
Connections – Electrical	32
Commissioning	34
Draining the solar collectors	36
Draining the water heater	36
Water supplies	38
Warranty	40

ABOUT YOUR WATER HEATER

MODEL TYPE

Congratulations for choosing a Rheem electric water heater and a Rheem solar conversion kit. The Rheem solar conversion kit converts your Rheem electric water heater into a Rheem solar Loline water heater. Your Rheem solar Loline water heater is designed for the solar collectors to be roof mounted and the solar storage tank to be installed at ground level. The solar storage tank is suitable for either outdoor or indoor installation. The system is suitable for installation, and offers protection against freeze damage, in areas up to 800 metres altitude. The system is not covered for freeze damage above 800 metres altitude (refer to “Warranty” on page 40).

The model you have chosen will be either a Rheemglas or an Optima model. The Optima model has a temperature adjusting knob on the lower front of the water heater. Both the Rheemglas and Optima models are available with either a single element or with twin elements (refer to “Single Element Models” on page 11 and “Twin Element Models” on page 11).

HOW HOT SHOULD THE WATER BE?

The solar control unit will circulate water through the solar collectors until a temperature of approximately 75°C is reached. During periods of low solar energy gain, the water temperature can be boosted by the thermostatically controlled electric booster heating unit. This may be operated manually or automatically depending on how it is wired. Refer to pages 12 and 13 or check with your electrician.

The Optima model features a user adjustable thermostat, which allows you to choose the most suitable boost temperature for your hot water needs. The Rheemglas model features a tradesperson adjustable thermostat. This requires a licensed tradesperson to make any temperature adjustments. The temperature is adjustable within the range shown in the diagram opposite.

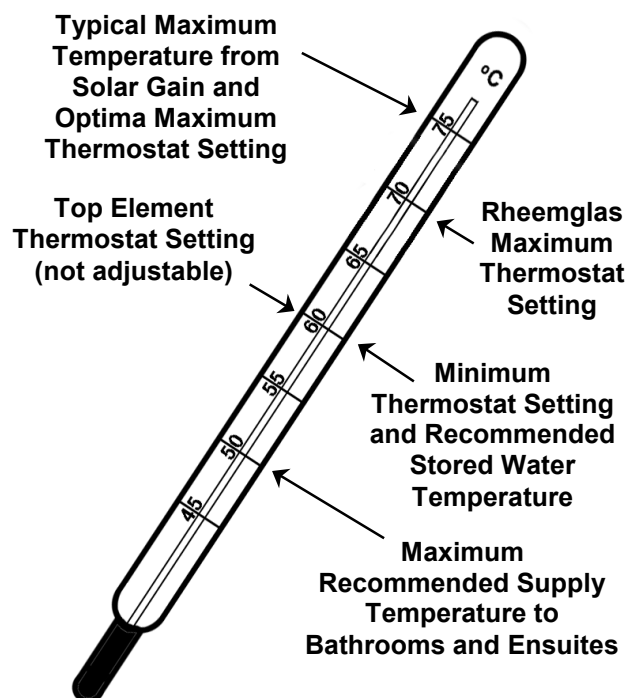

For reasons of safety and economy we advise you adjust the thermostat to the lowest setting which meets your needs, especially if there are young children or elderly people in the home.

ABOUT YOUR WATER HEATER

HOTTER WATER INCREASES THE RISK OF SCALD INJURY

We recommend, and it may also be required by regulations, that an approved temperature limiting device, such as the Rheem Temp-Set, be fitted into the hot water piping to the bathroom and ensuite when this water heater is installed. This will keep the water temperature below 50°C at the bathroom and ensuite. The risk of scald injury will be reduced and still allow hotter water to the kitchen and laundry. This temperature limiting device may be required by regulations.

TEMPERATURE ADJUSTMENT- OPTIMA

To adjust the temperature, push in the child resistant knob and turn anti clockwise to decrease or clockwise to increase the temperature setting. The Optima has a minimum temperature setting of 60°C and a maximum temperature setting of 75°C.

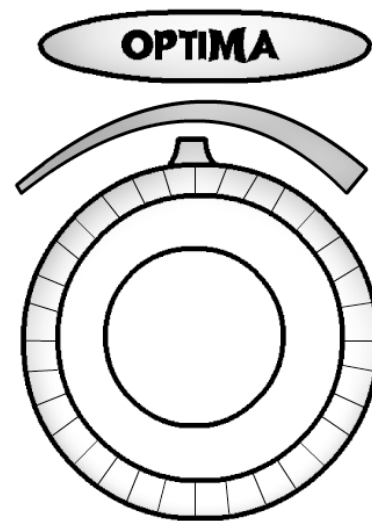

WARNING

This water heater is not intended to be operated, adjusted or tampered with by young children or infirm persons. Young children should be supervised to ensure they do not interfere with the water heater.

Care should be taken not to touch the pipe work connecting the solar collectors and the solar storage tank. Under certain conditions, very high temperature hot water can be generated by the solar collectors and flow through the pipe work.

TO TURN OFF THE WATER HEATER

If you plan to be away from home for a few nights, we suggest you leave the water heater switched on.

If it is necessary to turn off the water heater:

- Close the cold water isolation valve at the inlet to the water heater.
- Switch off the electrical supply at the isolating switch to the solar storage tank.
- Switch off the electrical supply at the power outlet to the solar control unit (refer to note below).

Note: If there is a risk of freezing conditions, the electrical supply to the solar control unit should not be switched off unless the solar collectors are drained, otherwise damage could result (refer to “Freeze Protection” on page 8).

ABOUT YOUR WATER HEATER

TO TURN ON THE WATER HEATER

- Open the cold water isolation valve fully at the inlet to the water heater.
- If the solar collectors and solar hot and cold pipes have been drained, it will be necessary to bleed the collector circuit (refer to “Bleeding the Solar Collectors” on page 7).

If the electrical supply to the water heater has been switched off:

- Switch on the electrical supply to the solar storage tank at the isolating switch
- Switch on the electrical supply to the solar control unit at the power outlet.

HOW DO I KNOW IF THE WATER HEATER IS INSTALLED CORRECTLY?

Installation requirements are shown on pages 23 and 26. The water heater must be installed by an authorised person and the installation must comply with national codes AS/NZS 3500.4.2, AS/NZS 3000, and all local codes and regulatory authority requirements. In New Zealand, the installation must conform with the New Zealand Building Code.

Note: The solar hot and cold pipe work between the solar storage tank and the solar collectors **must be** of copper and fully insulated with Armaflex insulation or similar (minimum thickness 10 mm). The insulation must be weatherproof if exposed and fitted up to the connections on the storage tank, as very high temperature water can flow from the solar collectors to the storage tank under certain conditions. Plastic pipe **must not** be used, as it will not withstand the temperature of the water generated by the solar collectors under certain conditions (refer to Warning on page 29).

DOES THE WATER QUALITY AFFECT THE WATER HEATER?

The water heater is suitable for most public water supplies, however some water qualities may have detrimental effects on the cylinder, solar collectors and fittings. **If you are in a known harsh water area you must read page 38.** If you are not sure, have your water quality checked against the conditions described on page 38.

HOW LONG WILL THE WATER HEATER LAST?

There are a number of factors that will affect the length of service the water heater will provide. These include the water quality, the water pressure, temperature (inlet and outlet) and the water usage pattern. However, your Rheem water heater is supported by a comprehensive warranty (refer to page 40).

ABOUT YOUR WATER HEATER

ANODE PROTECTION

The anode installed in your water heater will slowly dissipate whilst protecting the cylinder. The life of the water heater cylinder may be extended by arranging for an authorised person to inspect the anode and replacing it if required.

The suggested time after installation when the anode should be inspected is:

Rheemglas	8 years
Optima	10 years

For softened water supplies or in areas of poor water quality, it is recommended the anode be inspected 3 years earlier than shown (refer to “Water Supplies” on page 38).

BLEEDING THE SOLAR COLLECTORS

It is necessary to purge air from the collector circuit:

- When the water heater is to be turned on and the solar collectors and solar hot and cold pipes have been drained.
- After maintenance has been conducted on the pipe work and air has entered the system.
- If the circulator appears not to be circulating water around the system.

To purge air from the collector circuit:

- Ensure the solar storage tank is full of water and all of the hot taps are turned off.
- Using a flat blade screwdriver, open the bleed valve (if it is not already open) fitted adjacent to the 5 way tee at the cold water inlet of the water heater (see diagram).
- The mains pressure will force water to flow from the tank and through the pipe work, expelling air from the collector circuit through the bleed valve. This is evidenced by spurting of water from the drain line connected to the bleed valve.

Warning: Exercise caution, as water may be at a very high temperature.

- Close the bleed valve when water runs freely from the drain line.

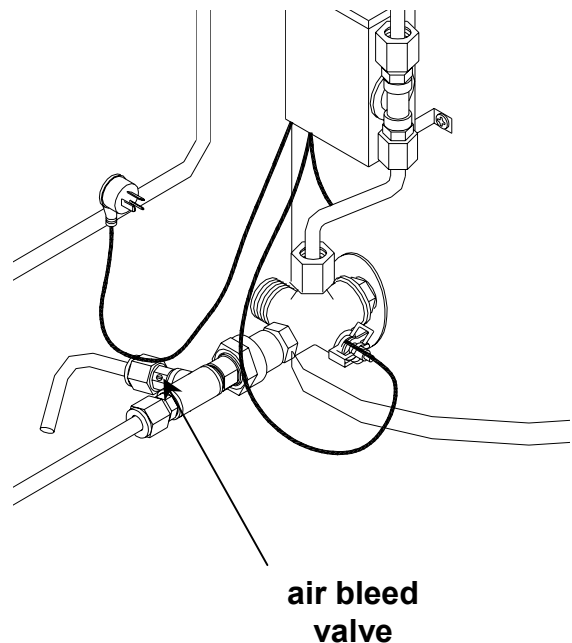

ABOUT YOUR WATER HEATER

FLUSHING THE SOLAR COLLECTORS

It may be necessary to flush the solar collectors if there is sediment in the water supply. To flush the solar collectors, follow the procedure “Bleeding the Solar Collectors” on page 7, allowing the water to flow from the bleed valve drain line for five minutes before closing the bleed valve.

It is recommended to flush the solar collectors every five years. This will assist in keeping the solar collectors, solar cold pipe and solar hot pipe clear of sediment.

FREEZE PROTECTION

The system is suitable for installation, and offers protection against freeze damage, in areas up to 800 metres altitude. The system is not covered for freeze damage above 800 metres altitude (refer to “Warranty” on page 40).

The anti freeze control is designed to recirculate a small amount of water from the solar storage tank through the solar pipe work during periods of low temperatures. This is to prevent the water inside the pipe work from freezing. It is essential that the electrical circuit to the solar control unit is continually turned on if there is a risk of freezing. The solar warranty does not cover damage caused by freeze conditions when the electrical circuit to the solar control unit is turned off or interrupted.

Notes:

- If it is necessary to switch the power off to the solar control unit and there is a risk of freezing, then it is necessary to have your plumber drain the solar collectors and solar flow and return pipe work.
- The freeze protection system will be rendered inoperable if electrical power is not available at the solar control unit. Damage caused by freezing due to no power at the solar control unit, is not covered by warranty.
- Pipe work between the solar collectors and solar storage tank must be insulated.
- The system is not covered for freeze damage above 800 metres altitude.
- Refer to “Warranty Exclusions” on page 39.

REGULAR CARE

TEMPERATURE AND PRESSURE RELIEF VALVE

This valve is near the top of the water heater and is essential for its safe operation. It is possible for the valve to release a little water through the drain pipe during each heating period. This occurs as the water is heated and expands by approximately 1/50 of its volume. **Never block the outlet of this valve or its drain pipe for any reason.**

Operate the easing lever on the temperature and pressure relief valve once every six months. **It is very important you raise and lower the lever gently.** If water does not flow freely from the drain line when the lever is lifted, then the water heater should be checked by the Rheem Service Department of their Accredited Service Agent.

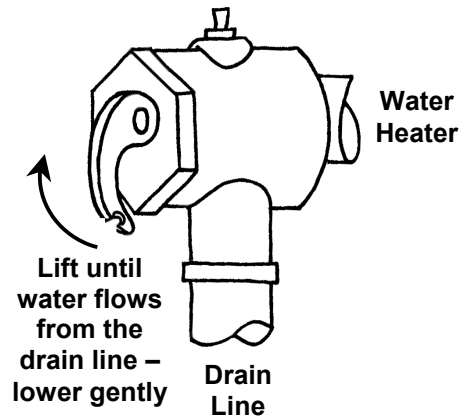

The temperature and pressure relief valve should be checked for performance or replaced at intervals not exceeding 5 years, or more frequently in areas where there is a high incidence of water deposits (refer to “Water Supplies” on page 38).

EXPANSION CONTROL VALVE

In South Australia and Western Australia an expansion control valve is fitted to the cold supply pipe to the water heater. Water will flow from its drain line during the heating period. In scaling water areas, an expansion control valve should be fitted to the cold water supply line to the water heater.

SAFETY

This water heater is supplied with a thermostat, an over-temperature cut-out, and a combination temperature and pressure relief valve. These devices must not be tampered with or removed. The water heater must not be operated unless each of these devices is fitted and is in working order.

If the power supply cord or plug to the solar control unit is damaged, it must be replaced by an authorised person, in order to avoid a hazard. Phone your nearest Rheem Service Department or Accredited Service Agent to arrange for an inspection.

The warranty can become void if relief valves or other safety devices are tampered with or if the installation is not in accordance with these instructions.

SOLAR COLLECTOR GLASS

Ensure the glass on your solar collectors is free of dust, salt spray or any other matter, which may reduce the effectiveness of the solar collectors. Hose or wash the collector glass with water and a soft brush when the solar collectors are cool. Trim any trees which may shade the solar collectors.

HOW YOUR WATER HEATER WORKS

The Rheem solar Loline system has its vitreous enamel lined solar storage tank installed at ground or floor level, remotely from the solar collectors. As the sun heats the water in the solar collectors the increase in temperature activates the circulator. The circulator then moves the water from the solar collectors through an insulated copper pipe to the solar storage tank. The circulator switches on whenever the water in the solar collectors is hotter than the water in the tank. Cooler water from the solar storage tank is circulated to the solar collectors to be heated by the sun's energy. This process continues while solar energy is available and until the water in the solar storage tank reaches a temperature of approximately 75°C.

MAINS PRESSURE

The water heater is designed to operate at mains pressure by connecting directly to the mains water supply. If the mains supply pressure in your area exceeds that shown on page 19, a pressure limiting valve must be fitted. The supply pressure should be greater than 350 kPa for true mains pressure operation to be achieved.

ELECTRIC BOOSTING

Water stored in the solar storage tank can be heated by an electric booster heating unit. The booster heating unit is for heating the water at times of low solar energy gain, such as during very cloudy or rainy weather, or during the winter months.

The booster heating unit is controlled by an electric thermostat. The thermostat and its over temperature energy cut out are mounted on the solar storage tank behind the front cover. The water temperature is automatically controlled to the thermostat setting when the booster heating unit is energised.

The Optima models feature a user adjustable thermostat, which allows you to choose the most suitable boost temperature for your hot water needs. It has a minimum temperature setting of 60°C and a maximum temperature setting of 75°C. The thermostat on the Rheemglas models is tradesperson adjustable. It has a minimum temperature setting of 60°C and a maximum temperature setting of 70°C. It can only be adjusted by an authorised person. Automatic safety controls are fitted to the water heater to provide safe and efficient operation.

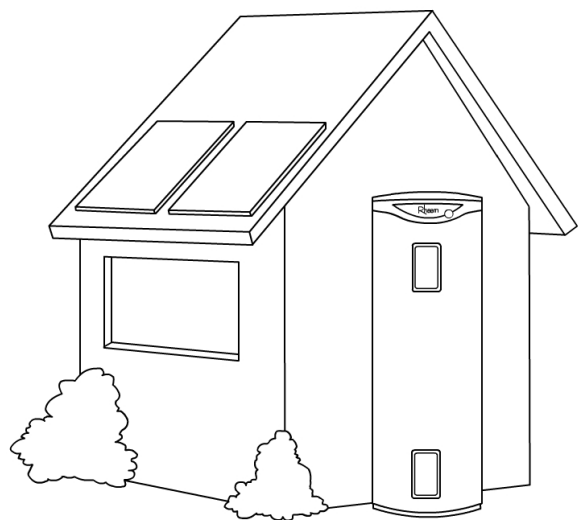

HOW YOUR WATER HEATER WORKS

SINGLE ELEMENT MODELS

- **Continuous electricity supply**
This type of connection is suited to where the storage capacity is less than the normal daily usage.
- **Off-Peak electricity supply**
This type of connection will only allow boosting to occur during set hours. A volume of water sufficient for the day's total use is heated and stored. This type of boosting may be more economical due to reduced tariffs by the electricity authority.

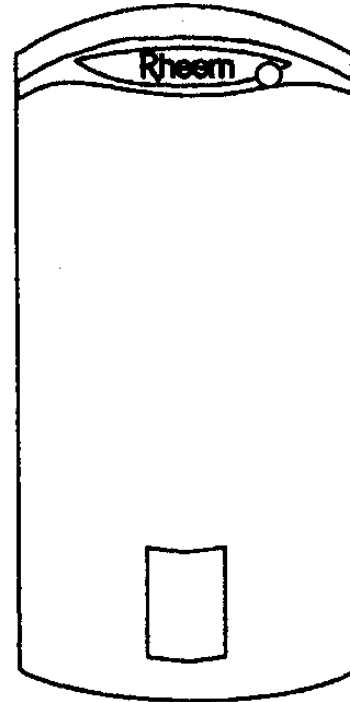

TWIN ELEMENT MODELS

This type of water heater has two heating units, each with its own thermostat. One heating unit is at the base of the water heater and the other near the top.

- **Lower heating unit**
During normal operation this heating unit supplies all of the boosted hot water during periods of low solar energy gain.
- **Top heating unit**
This heating unit only operates during periods of high demand to provide an additional supply of boosted water.
- **Electrical connection**
The two heating units are wired for non simultaneous operation and only one heating unit can operate at a time. The lower heating unit is usually connected to the Off-Peak electricity supply and the top heating unit to a continuous supply. Some electricity suppliers allow both heating units to be metered at the Off-Peak or controlled tariff.

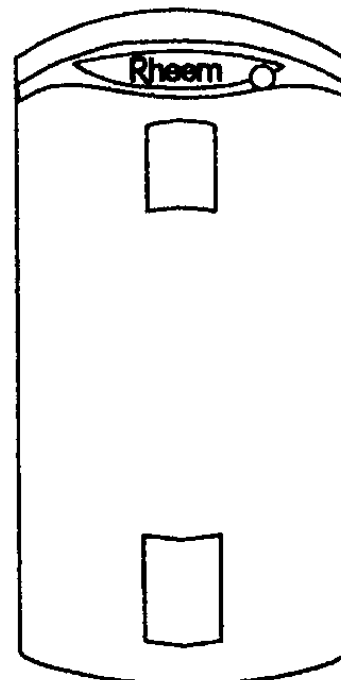

NOTE: Power must be available to the top heating unit circuit at all times for this water heater to operate as designed.

HOW YOUR WATER HEATER WORKS

MANUAL CONTROLS

An isolating switch is installed in your electrical meter box for your solar water heater. Rheem recommends as an optional extra a second switch, called the Booster Switch, be installed in a convenient location such as the kitchen or laundry. This switch should be a normal on/off manually operated switch (recommended for Off-Peak electricity supplies to single element models and the bottom element on twin element models) or the Rheem “One Shot Control” switch (recommended for continuous electricity supplies to single element models only).

The amount of water heated by the booster heating unit depends on the model of water heater installed. The boosted volumes of hot water are:

Model	250 L	315 L	400 L
Lower Heating Unit (all models)	250 litres	315 litres	400 litres
Top Heating Unit (twin element models)	50 litres	50 litres	90 litres

MANUAL ON/OFF SWITCH

(a) Continuous Tariff Connection

Operate the booster switch to activate the auxiliary booster heating unit when the hot water falls below an acceptable temperature. It is important to ensure the booster switch is turned OFF after you have satisfied your hot water needs. Do not leave the booster switch ON in sunlight hours because your solar savings will be reduced.

(b) Extended Off-Peak Tariff Connection

Operation is very similar to that suggested for continuous tariff, but it is important to be aware of the hours during which electricity is available so boosting, if required, can be adapted to suit. (Check with your local Electricity Supply Authority for hours of operation). Do not leave the booster switch on during daylight hours unless boosting is required, as solar savings will be reduced.

(c) Off-Peak (night rate) Tariff Connection

Most systems will be connected to an Off-Peak supply of electricity. Boosting will only occur overnight (usually between 11:00 PM and 6:00 AM). In the winter months many households will find it necessary to leave the booster switch ON. However, in some cases it may only be necessary to switch the booster switch ON every second night. This can be determined over a trial period.

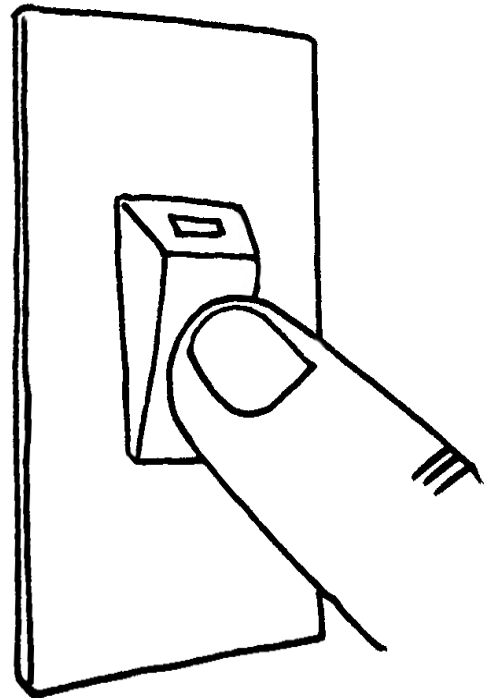

HOW YOUR WATER HEATER WORKS

“ONE SHOT CONTROL” SWITCH

The “One Shot Control” switch has been specially developed to help provide maximum savings with electrically boosted solar water heaters connected to a **continuous** electricity supply. Power must be available to the “One Shot Control” switch before the booster heating unit can be activated.

The switch has a push button operation and incorporates a neon light indicator. This neon light will come on when the water in the boosted section of the solar storage tank falls more than 6°C below the thermostat setting, indicating boosting may be required.

When you decide the hot water is below a usable temperature and additional hot water is required, press the control button. The neon light will go out and the booster heating unit will be turned “ON”. The booster heating unit is automatically turned “OFF” when the water temperature reaches the thermostat setting.

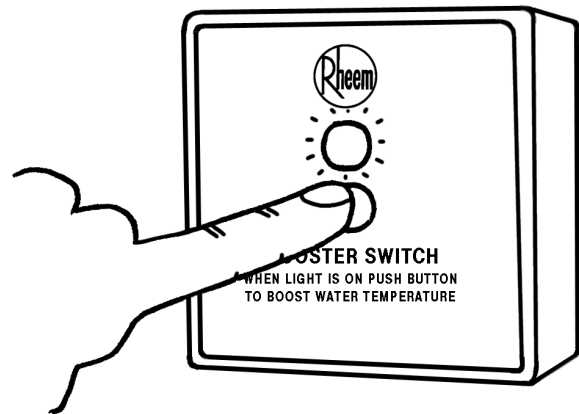

It is not necessary to activate the booster heating unit every time the neon light is on (the neon light indicates the water is more than 6°C below the thermostat setting). The water may still be at a usable temperature for some purposes (e.g. showering) and you may not need to use hot water for some hours during which time the water may be heated by the sun.

Remember, even on cloudy days your solar water heater can receive diffused radiation, which will heat some of your stored water. On these days you will need to operate the booster heating unit only as desired. For summer operation it is recommended trial periods be undertaken to determine if it is necessary to turn the booster switch or one shot control ‘on’ at all.

GOING ON HOLIDAYS

If you plan to be away from home for a few nights, we suggest you leave the water heater switched on. If you plan to be away for a longer period, conserve energy by switching the booster switch “OFF”. It is not necessary to switch off the electrical supply at the power outlet to the solar control unit. Refer to “To Turn Off The Water Heater” on page 5. Also if the system is not used for a period in excess of 4 weeks it is recommended the solar collectors be covered.

SAVE A SERVICE CALL

Check the items below before making a service call. You will be charged for attending to any condition or fault that is not related to manufacture or failure of a part.

NOT ENOUGH HOT WATER (OR NO HOT WATER)

- **Insufficient sunlight**

Insufficient sunlight due to cloudy weather during summer months or low solar energy contribution in winter months may mean you will need to switch on the booster heating unit more often.

- **Booster heating unit not operating**

Inspect the isolating switch marked “HOT WATER” or “WATER HEATER” switchboard and the booster switch (if one is installed) and ensure they are turned “ON”. Check the electrical tariff to which the unit is connected. If on Off-Peak remember heating hours are restricted (refer to “Off-Peak Tariff” on page 12). Check the fuse marked “water heater”.



Check the fuse marked “HOT WATER” or “WATER HEATER” at the switchboard.

- **Twin element models**

For twin element non simultaneous models power must be available to the top heating unit circuit at all times for this water heater to operate as designed.

- **Solar Control Unit**

Check the power outlet to the solar control unit is switched on.

- **Collectors shaded**

If trees or other objects shade the solar collectors or if the glass is dirty, the effectiveness of the solar collectors will be greatly reduced. Clean the collector glass, trim trees or relocate the solar collectors if the obstruction is permanent.

- **Collector area is too small**

For most installations, the number of solar collectors recommended in Rheem literature has been proven to provide the required solar energy to meet the average family needs. However, in some circumstances, it may be necessary to install an additional solar collector.

SAVE A SERVICE CALL

- **Air in collectors (no solar gain)**

It is possible under certain conditions, such as when the pipe work has been opened, that air may become trapped in the solar collectors. This will prevent the circulator from moving water around the collector circuit. The air will need to be purged from the solar collectors (refer to “Bleeding The Solar Collectors” on page 7).

- **Are you using more hot water than you think?**

Is one outlet (especially the shower) using more hot water than you think? Carefully review the family’s hot water usage. As you have installed an energy saving appliance, energy saving must also be practised in the home. Adjust your water usage pattern to take advantage of maximum solar gains. Still have enjoyable showers, but restrict the amount of hot water used by simply fitting an inexpensive flow control valve to your shower rose.

- **Temperature and pressure relief valve running**

Is the relief valve discharging too much water? (Refer to “Temperature and Pressure Relief Valve Running” on page 16).

- **Thermostat setting**

Ensure the thermostat setting is appropriate. You may choose to adjust (Optima models) or have your electrician adjust (Rheemglas models) the thermostat upwards to gain additional hot water capacity when boosting.

- **Water heater size**

Do you have the correct size water heater for your requirements? The sizing guides in the sales literature and on the Rheem website (www.rheem.com.au) suggest average sizes that may be needed.

WATER NOT HOT ENOUGH

You may find that due to heavy hot water usage or low solar energy gain the water temperature may be lower than normally expected. You will need to carefully plan your use of the booster heating unit to boost the water temperature on such occasions.

A lower water temperature may also be noticed in the morning when the booster heating unit has not been switched on overnight. This in particular may be experienced during periods of low solar energy gain, or if there has been heavy hot water usage the previous night.

SAVE A SERVICE CALL

TEMPERATURE AND PRESSURE RELIEF VALVE RUNNING

- **Normal Operation**

It is normal and desirable this valve allows a small quantity of water to escape during the heating cycle. However, if it discharges more than a bucket full of water in 24 hours, there may be another problem.

- **Continuous dribble**

Try gently raising the easing lever on the relief valve for a few seconds. (refer to "Temperature and Pressure Relief Valve" on page 9). This may dislodge a small particle of foreign matter and clear the fault. Release the lever gently.

- **Steady flows for long period (often at night)**

This may indicate the mains water pressure sometimes rises above the designed pressure of the water heater. Ask your installing plumber to fit a pressure limiting valve.

NEVER replace the relief valve with one of a higher pressure rating.

- **Heavy flows of hot water until the water heater is cold - then stops until water reheats**

The water heater **must** be switched off at the isolating switch or switchboard. Phone your nearest Rheem Service Department or Accredited Service Agent to arrange for an inspection.

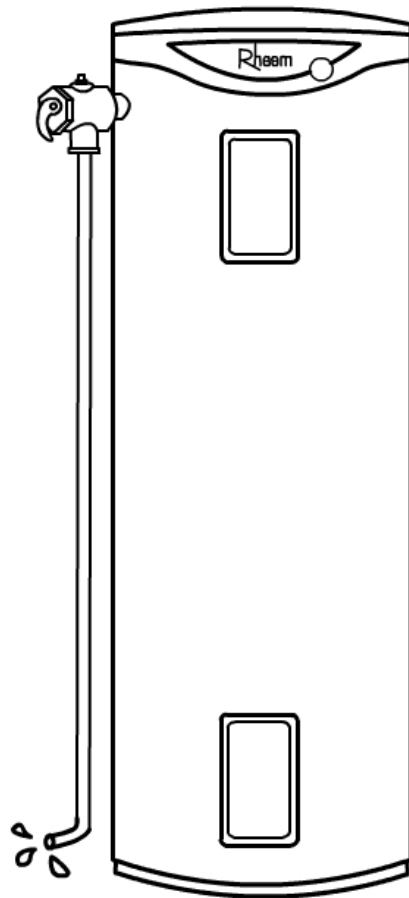

EXPANSION CONTROL VALVE RUNNING

If an expansion control valve is fitted in the cold water line to the water heater (refer to page 21) it may discharge a small quantity of water instead of the Temperature and Pressure Relief valve on the water heater. The benefit is that energy is conserved as the discharged water is cooler.

SAVE A SERVICE CALL

HIGH ELECTRICITY BILLS

With the installation of your new solar hot water system, maximum electrical energy savings can be achieved with careful planning of hot water usage. Should you at any time, feel your electricity account is too high, we suggest you check the following points:

- Is the relief valve running excessively? (Refer to “Temperature and Pressure Relief Valve Running” on page 16).
- Is one outlet (especially the shower) using more hot water than you think? (Refer to “Not Enough Hot Water” on page 14).
- Is there a leaking hot water pipe, dripping hot water tap, etc? Even a small leak will waste a surprising quantity of hot water and energy. Replace faulty tap washers, and have your plumber rectify any leaking pipe work.
- Are you using the booster heating unit properly? (Refer to “Manual On/Off Switch” on page 12 and “One Shot Control Switch” on page 13)
- Consider recent changes to your hot water usage pattern and check if there has been any increase in tariffs since your previous account.

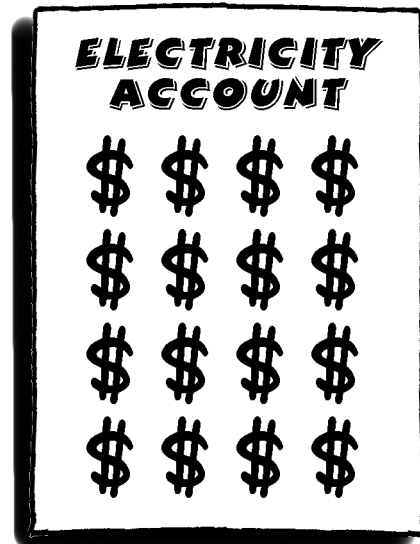

ELECTRICITY TARIFFS

The electricity tariff to which your solar water heater is connected will play an important role in the overall effectiveness of the system. It is important you are aware of this tariff to enable you to take full advantage of the boosting period, i.e. Domestic/Continuous, Off-Peak, Extended Off-Peak. For types of tariffs (refer to “How Your Water Heater Works” on page 12).

COLLECTOR GLASS

Warranty **DOES NOT** cover breakage of solar collector glass. Check your household insurance policy covers collector glass breakage. **Warning:** Collector glass should not be replaced whilst the solar collector is on the roof. The solar collector must be disconnected and brought to ground level before replacing the collector glass. Should the glass on a solar collector require replacement, contact your nearest Rheem Service Office or Accredited Service Agent.

IF YOU HAVE CHECKED ALL THE FOREGOING AND STILL BELIEVE YOU NEED ASSISTANCE, CALL YOUR NEAREST RHEEM SERVICE OFFICE OR ACCREDITED SERVICE AGENT.

INSTALLATION – SOLAR STORAGE TANK

The system is suitable for installation, and offers protection against freeze damage, in areas up to 800 metres altitude. The system has NO WARRANTY for freeze damage above 800 metres altitude (refer to “Warranty” on page 40).

THIS WATER HEATER IS NOT SUITABLE FOR POOL HEATING.

SOLAR WATER HEATER STORAGE TANK LOCATION

The solar water heater storage tank is suitable for either outdoor or indoor installation. Whether located outdoor or indoor, the solar water heater storage tank should be installed close to the most frequently used outlet and its position chosen with safety and service in mind.

Clearance must be allowed for servicing of the water heater. The solar water heater storage tank must be accessible without the use of a ladder or scaffold. Make sure the Temperature and Pressure Relief valve lever is accessible and the front cover, thermostat and booster heating unit can be removed for service.

You must be able to read the information on the rating plate. If possible leave headroom of one water heater length so the anode can be inspected or replaced. Remember you may have to remove the entire water heater later for servicing.

The installation must comply with the requirements of AS/NZS 3500.4.2, AS/NZS 3000, and all local codes and regulatory authority requirements. In New Zealand, the installation must conform with the New Zealand Building Code.

It is recommended the solar storage tank be installed at ground or floor level and must stand vertically upright. Remember all local authorities have regulations about putting water heaters into roof spaces.

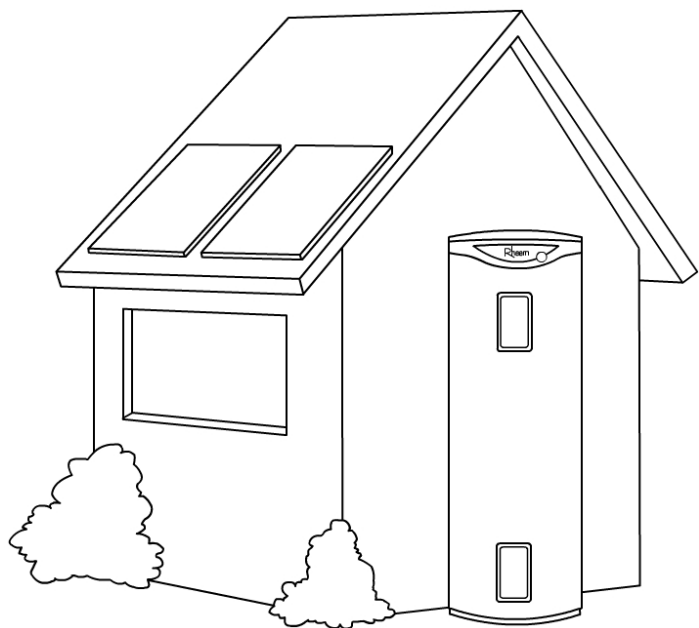

INSTALLATION – SOLAR STORAGE TANK

SAFE TRAY

It is a requirement of the National Plumbing Code AS/NZS 3500.4.2 that for new installations all water heaters be installed in a safe tray where in the event of a leak, property may be damaged. Installation of such trays must comply with Clause 4.4 and Sub-clauses 1 to 5 of the above mentioned code.

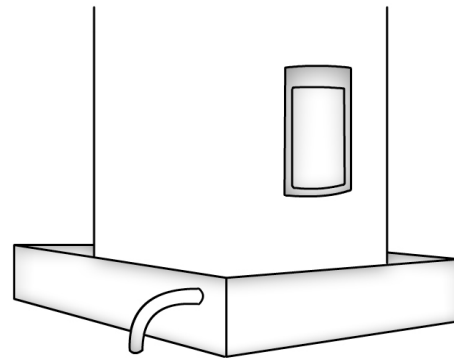

MAINS WATER SUPPLY

Where the mains water supply exceeds that shown in the table below, an approved pressure limiting valve is required and should be fitted as shown in the installation diagram (refer to diagram on page 21).

Model	250, 315, 400 litre
Relief valve setting	1000 kPa
Expansion control valve setting *	850 kPa
Max. mains supply pressure	
With expansion control valve	680 kPa
Without expansion control valve	800 kPa

* Expansion control valve not supplied with the water heater.

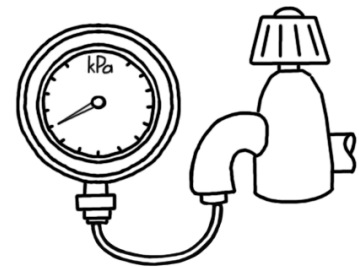

TANK WATER SUPPLY

If the water heater is supplied with water from a tank supply, then the bottom of the supply tank must be at least 1 m above both the solar collectors and the highest hot water outlet. Take care to avoid air locks. The cold water supply line to the water heater should be adequately sized and fitted with a full flow gate valve or ball valve.

HOT WATER DELIVERY

This water heater can deliver water at temperatures which can cause scalding. It is necessary that a temperature limiting device, such as the Rheem Temp-Set, be fitted between the water heater and the outlets in any ablution area, such as a bathroom or ensuite, when this water heater is installed, to reduce the risk of scalding. The installing plumber may have a legal obligation to ensure the installation of this water heater meets the delivery water temperature requirements of AS/NZS 3500.4.2 so that scalding water temperatures are not delivered to a bathroom, ensuite or other ablution area (refer to diagram on page 21).

INSTALLATION – SOLAR STORAGE TANK

REDUCING HEAT LOSSES

We recommend the first 1.5 to 2 m of the hot water line coming out of the water heater be insulated with weatherproof insulation. In addition, the insulation of the hot water line from the water heater must comply with the requirements of AS/NZS 3400.4.2.

ANODE TYPES

The correct anode type for the water supply being used must be fitted in the water heater (refer to “Water Supplies” on page 38). The black anode is standard.

Total Dissolved Solids in water supply to the water heater	Anode colour code
0 – 40 mg/L	Green
40 – 600 mg/L	Black
600 – 2500 mg/L	Blue

SADDLING - PIPE WORK

To prevent damage to the cylinder when attaching pipe clips or saddles to the water heater jacket, we recommend the use of self-drilling screws with a maximum length of 12 mm. Should pre drilling be required, extreme caution must be observed when penetrating the jacket of the water heater.

Note: Damage to the cylinder as a result of saddling to the jacket will void the warranty.

BOOSTER HEATING UNIT

The booster heating unit(s) provides hot water during periods of low solar gain. Single element models can be connected to either an Off-Peak electricity supply or a continuous electricity supply. Twin element models are to be connected with the bottom heating unit on an Off-Peak electricity supply and the top heating unit on a continuous electricity supply. Boosting can be controlled via a user operated manual switch. Refer to “Manual Controls” on page 33.

INSTALLATION – SOLAR STORAGE TANK

ASSEMBLY OF COLD WATER SUPPLY AND SOLAR PIPE CONNECTIONS

Use thread sealing tape or approved thread sealant on all fittings.

All compression fittings must use brass or copper olives.

Ensure the air bleed valve is open when filling collectors.

HOT WATER OUTLET

Provide a union for disconnection. Insulate pipe.

COLD WATER INLET

See cold water connection detail as applicable to your local requirements. Provide a union for disconnection.

RELIEF VALVE

A drain pipe must be fitted (refer to page 30).

BLEED VALVE

A drain pipe must be fitted (refer to page 30).

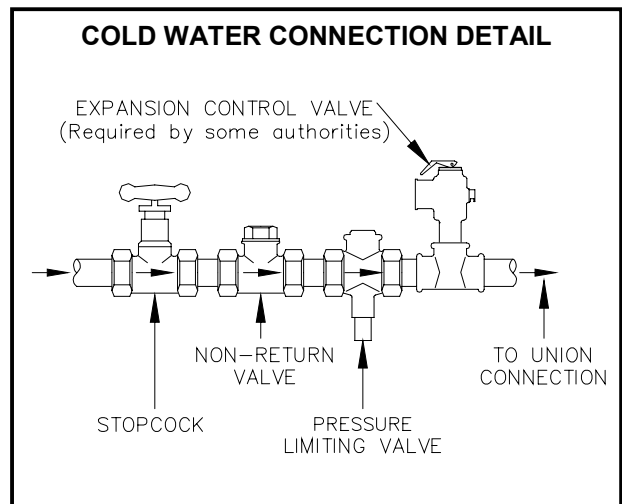
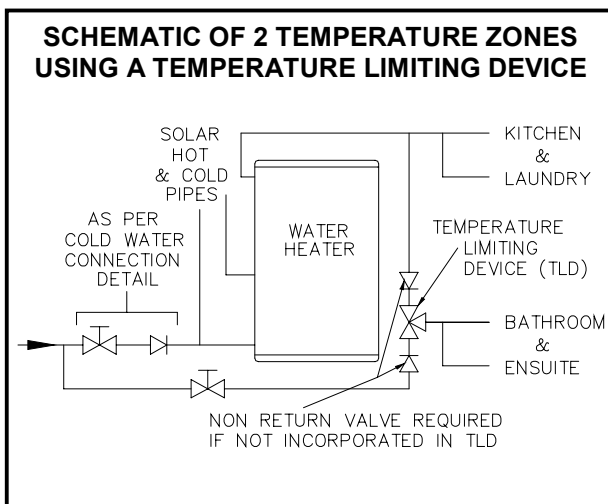

INSTALLATION – SOLAR STORAGE TANK

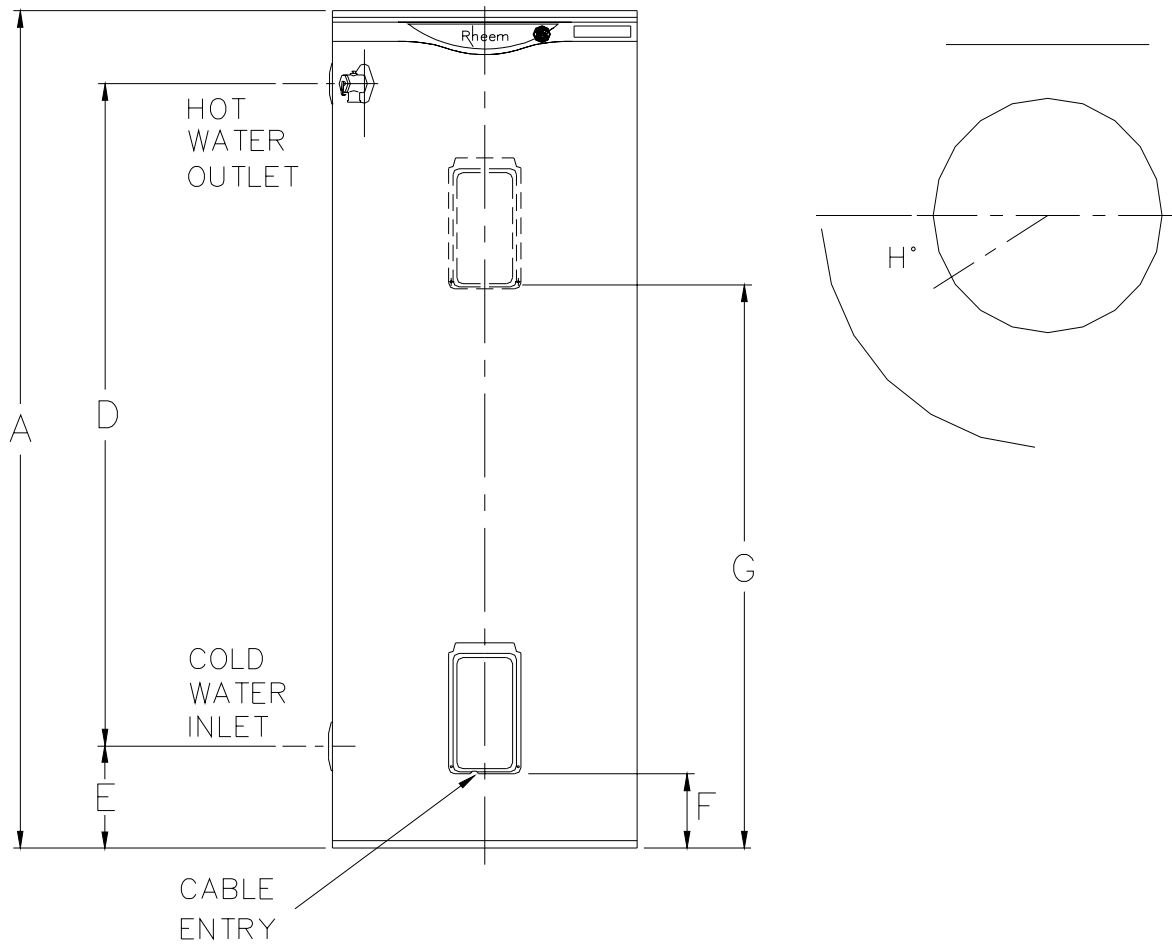

Rheemglas	Single Element		111250	111315	111400
	Twin Element		162250	162315	162400
Optima	Single Element		411250	411315	411400
	Twin Element		462250	462315	462400
Storage Boost		Litres	270	340	423
	Top	Litres	50	50	90
	Bottom	Litres	250	315	400
Dimensions	A	mm	1390	1700	1880
	B	mm	650	650	690
	C	mm	695	695	735
	D	mm	1117	1417	1559
	E	mm	74	74	80
	F	mm	155	155	155
	G	mm	1005	1305	1386
	H	degrees	32	32	30
J	degrees	88	88	83	
Weight	empty	kg	72	97	118
	full	kg	342	437	544

INSTALLATION – SOLAR STORAGE TANK

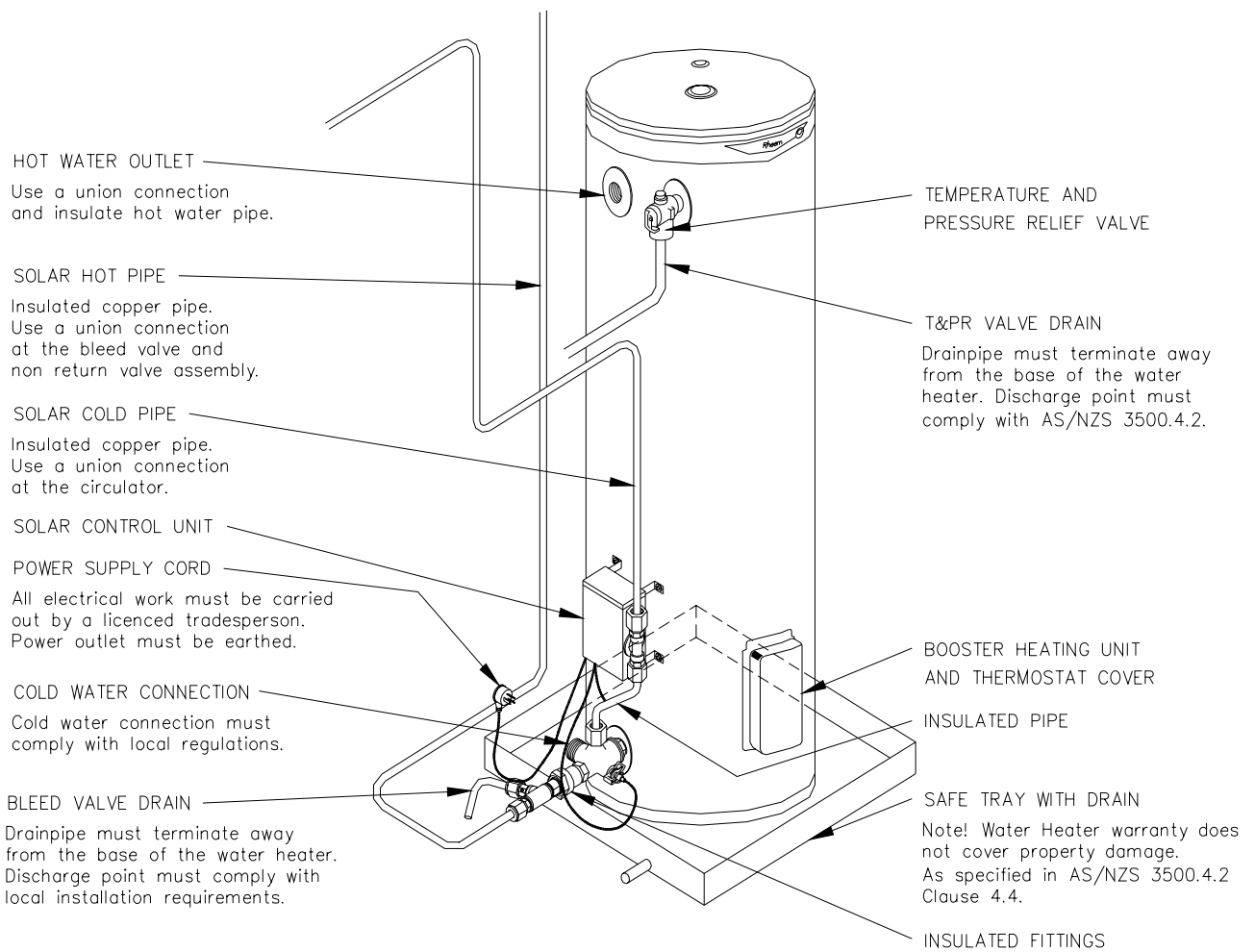

INDOOR LOCATION

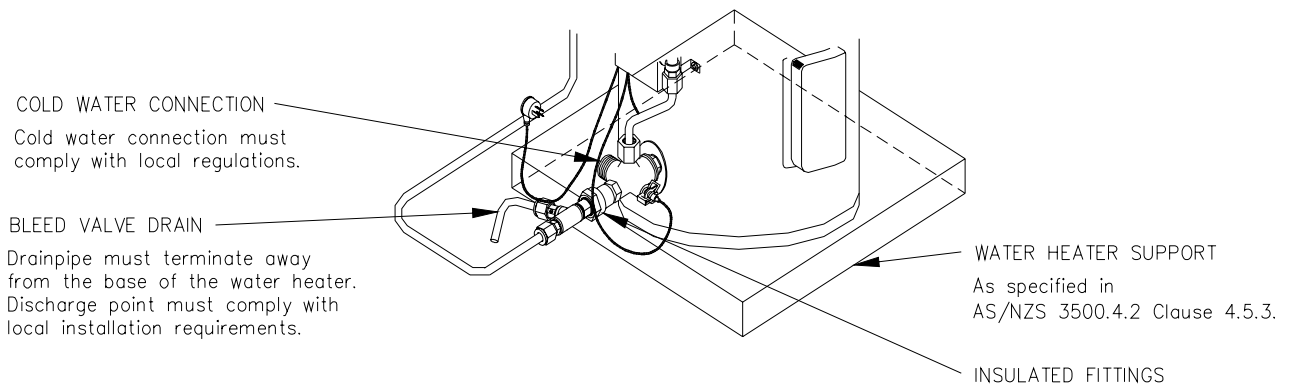

OUTDOOR LOCATION

INSTALLATION – SOLAR CONTROL UNIT

The solar control unit is designed to be mounted on the side of the solar storage tank, with its location above and offset from the cold water inlet. The solar control unit, supplied with a 1.8 metre power cord, requires a 220 – 240 V general power outlet (GPO) located within 1.2 metres of its installation. If the installation is outdoors, the power outlet must be weatherproof (refer to “Connections – Electrical” on page 32).

Note: Care must be taken when mounting the solar control unit to the side of the solar storage tank. Damage to the cylinder as a result of mounting the solar control unit to the jacket will void the warranty (refer to “Saddling - Pipe Work” on page 20).

SOLAR CONVERSION OF A RHEEM ELECTRIC WATER HEATER

To connect the solar cold and hot pipes and mount the solar control unit on a Rheem electric water heater (without a raised solar hot inlet):

Numbers in parentheses refer to items on diagram on page 26.

- Fit the 5 way tee (2) to the cold water inlet of the solar storage tank. Ensure the rounded tube (snorkel) is orientated upwards when inserted into the solar storage tank, the cold sensor housing is orientated horizontally to the front of the solar storage tank and the solar cold outlet is orientated vertically upwards.
- Connect the DN15 preformed pipe (4) to the solar cold outlet connection, using the compression nut (5) and olive (6) provided.
- Fit a BSP $\frac{1}{2}$ " x G $\frac{1}{2}$ " nipple (1) to the **outlet** of the circulator (7) in the solar control unit (8) (ensure the compression end of the nipple is exposed).
- Locate the solar control unit (8) by connecting the DN15 preformed pipe (4) to the nipple on the **inlet** of the circulator (7) using the compression nut (5) and olive (6) provided.
- Secure the solar control unit (8) to the solar storage tank using the four screws (9) provided.
- Connect the solar cold pipe (to the collector) to the nipple (1) on the outlet side of the circulator (7) using the compression nut (5) and olive (6) provided.
- Insert the cold sensor probe (10) into the cold sensor housing on the 5 way tee (2), ensuring the 'O' ring is in position on the probe. Lock it into position with the locking washer and clip provided.
- Connect the hot sensor lead (from the solar collector installation) to the hot sensor cable connector at the underside of the solar control unit (8).

INSTALLATION – SOLAR CONTROL UNIT

- Insulate the preformed pipe (4) with the 280 mm long x 12 mm diam insulation (12) and secure with the cable ties (14) provided
- Fit the air bleed valve and non return valve assembly (11) to the solar hot water inlet of the 5 way tee (2). Ensure the bleed valve outlet is orientated downwards at a slight angle to the horizontal and to the rear of the solar storage tank.
- Connect a drain line to the bleed valve (refer to “Bleed Valve Drain” on page 30).
- Fit a BSP $\frac{1}{2}$ ” x G $\frac{1}{2}$ ” nipple (1) to the end (inlet) of the air bleed valve and non return valve assembly (11) (ensure the compression end of the nipple is exposed).
- Connect the solar hot pipe (from the collector) to the nipple (1) on the air bleed valve and non return valve assembly (11) using the compression nut (5) and olive (6) provided.
- Insulate the air bleed valve and non return valve assembly (11) and 5 way tee (2), from the solar hot pipe to the inlet of the solar storage tank, with the 220 mm x 35 mm diam insulation (13) and secure with the cable ties (14) provided.

Note: Use thread sealing tape or an approved thread sealant on all fittings.

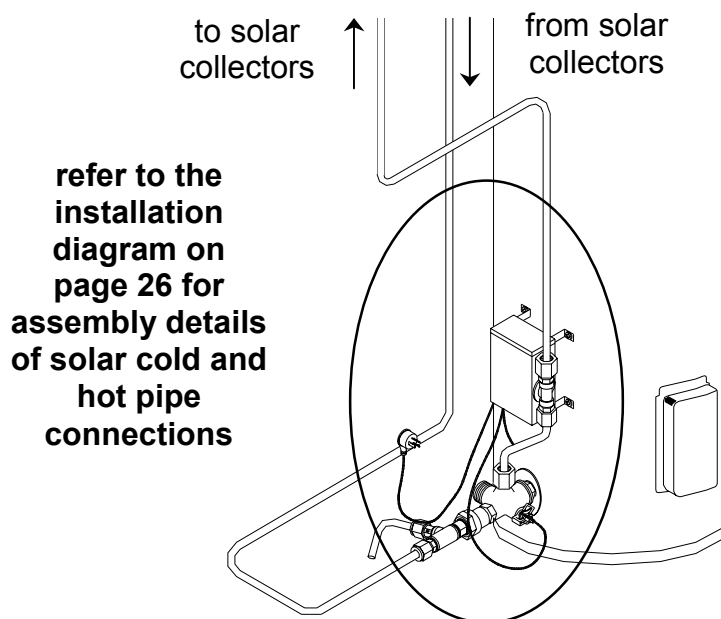

Solar Storage Tank with Solar Control Unit

INSTALLATION – SOLAR CONTROL UNIT

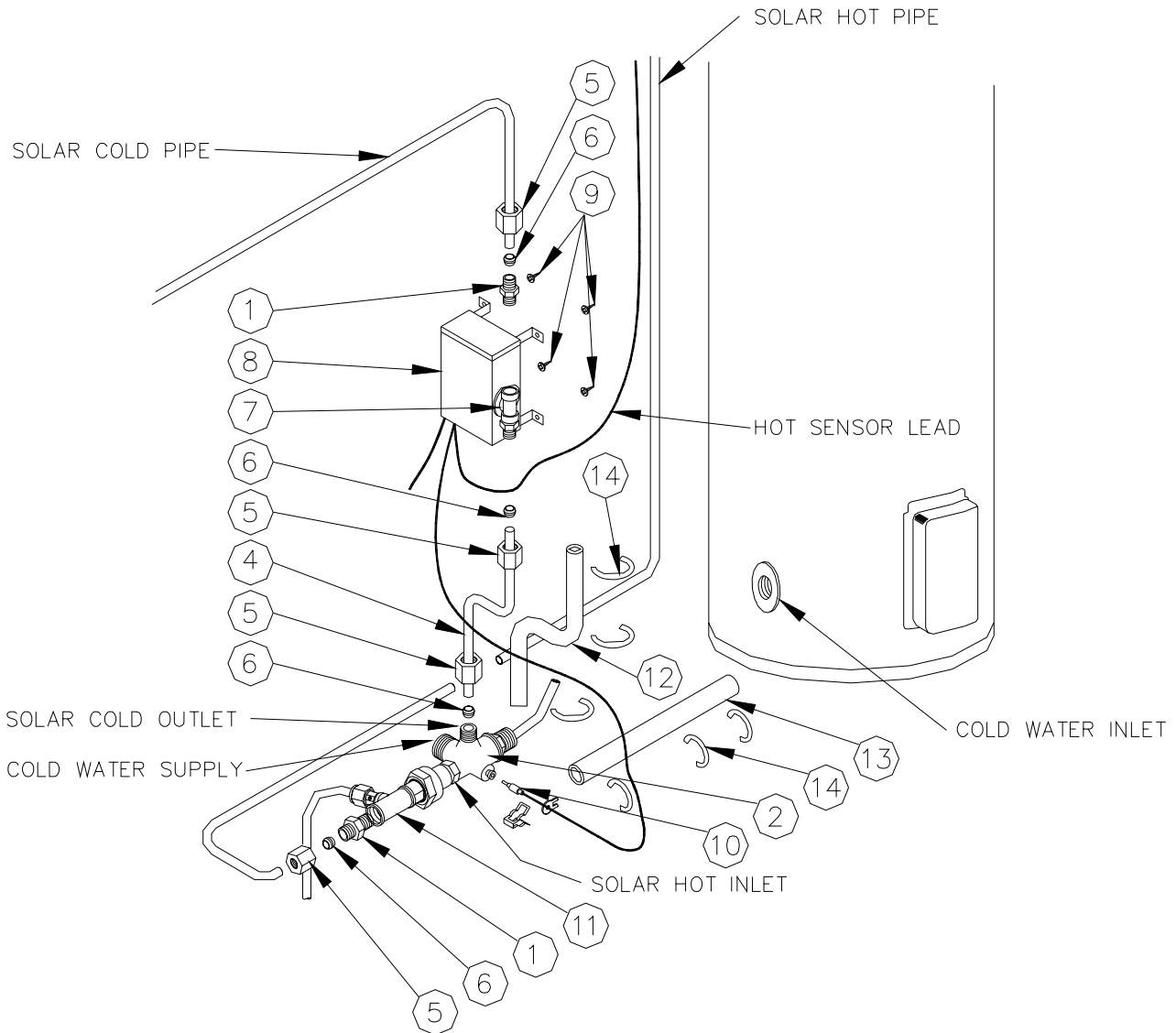

SUPPLIED IN SOLAR LOLINE CONVERSION KIT

- | | |
|---|---|
| 1. Nipple BSP $\frac{1}{2}$ " X G $\frac{1}{2}$ " | 9. Screws |
| 2. 5 way tee | 10. Cold sensor probe |
| 4. Preformed pipe DN15 | 11. Air bleed valve and non return valve assembly |
| 5. Compression nut | 12. Insulation 280 mm long x 12 mm diam |
| 6. Olive | 13. Insulation 220 mm long x 35 mm diam |
| 7. Circulator | 14. Cable tie |
| 8. Solar control unit | |

INSTALLATION OF SOLAR COLLECTORS

Refer to page 27 for information on solar collector location. Refer to the installation instructions supplied with the collector kit for details on the installation of the solar collectors.

INSTALLATION – SOLAR COLLECTORS

SOLAR COLLECTOR LOCATION

Solar collectors must be installed in a shade free position and located as follows:

- The solar collectors are to be installed facing toward the equator (i.e. north facing in the southern hemisphere and south facing in the northern hemisphere). Where this orientation is not practical, a system facing up to 45° from the equator will have its efficiency reduced by approximately 5%.
- Inclination of the solar collectors should be approximately equal to the local latitude angle. The latitudes of some Australian cities are listed below. Solar collectors may be installed at the roof angle for simplicity of installation and appearance, but must never be flat. If the roof angle varies by 15° from the correct angle, efficiency will be reduced by 5%.
- A flat roof stand is required for installations where the roof angle is less than 10°.
- The collector kit is suitable for installations with an inclination of up to 30°. Where the solar collectors are installed at inclinations greater than 30°, special roof fixings may be necessary. Refer to your local Rheem Solar Distributor for details.
- The installation of the solar collectors must comply with the requirements of AS/NZS 3500.4.2 and all local codes and regulatory authority requirements.
- The roof must be suitable to take the mass of the solar collectors. Each solar collector weighs 34 kg when full of water.

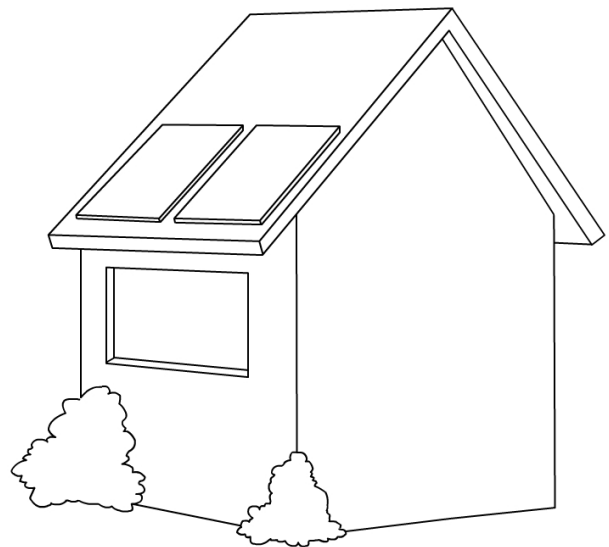
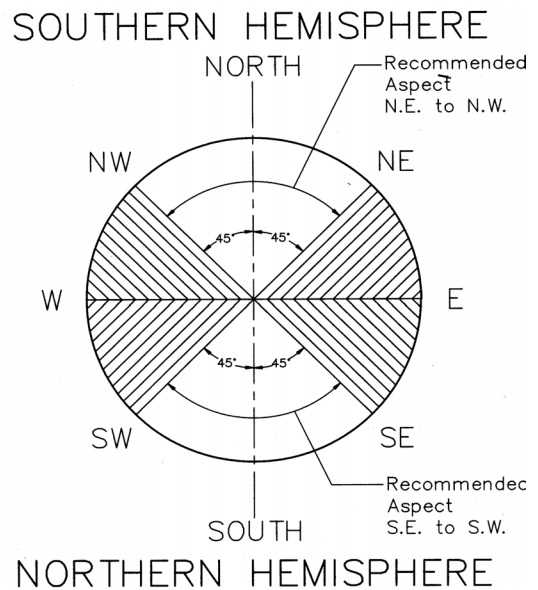

Latitude of Some Australian Cities

Adelaide	35°S	Cairns	17°S	Hobart	42°S	Port Hedland	20°S
Alice Springs	24°S	Canberra	35°S	Mildura	34°S	Rockhampton	24°S
Brisbane	27°S	Darwin	12°S	Melbourne	38°S	Sydney	34°S
Broken Hill	31°S	Geraldton	28°S	Perth	32°S	Townsville	19°S

CONNECTIONS - PLUMBING

CONNECTION SIZES

- Hot water connection: RP $\frac{3}{4}$ /20.
- Cold water connection: R $\frac{3}{4}$ /20.
(cold water inlet to tank: RP $\frac{3}{4}$ /20).
- Solar hot (from collector) connection: DN15 compression fitting.
- Solar cold (to collector) connection: DN15 compression fitting.
- Relief valve connection: RP $\frac{1}{2}$ /15.
- Bleed valve connection: G1.0B.
- Expansion control valve connection (when fitted): RP $\frac{1}{2}$ /15.

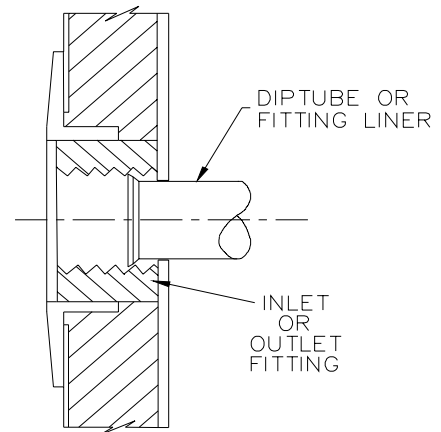

INLET/OUTLET CONNECTIONS

A disconnection union must always be provided at the cold water inlet and hot water outlet on the water heater to allow for disconnection of the water heater.

All water heaters have a plastic dip tube or fitting liner in the inlet and outlet fittings (see diagram). These must be in place for the water heater to function properly. Do not remove or damage them by using heat nearby. They will be pushed into the correct position as the fitting is screwed in.

A non return valve must be installed on the cold water supply pipe to the solar storage tank. Use the arrangement shown in the installation diagram (refer to page 21). The plumbing arrangements for the cold water inlet and solar cold and hot pipes are shown on page 26. The pipe work must be cleared of foreign matter before connection and purged before attempting to operate the water heater.

PIPE SIZES

The solar cold and hot pipes between the solar storage tank and the solar collectors should be a minimum DN15. The cold water pipe to the water heater should be the same size or bigger than the hot water line from the water heater. For best results, choose the most suitable pipe size for each individual application. Refer to the relevant plumbing regulations.

CONNECTIONS - PLUMBING



WARNING: Plumber – Be Aware:

- The solar cold and hot pipes between the solar storage tank and the solar collectors **MUST BE** of copper and fully insulated with Armaflex insulation or similar (minimum thickness 10 mm).
- The insulation must be weatherproof if exposed and **fitted up to the connections on both the solar collectors and the storage tank**, as very high temperature water can flow from the solar collectors to the solar storage tank under certain conditions. The insulation will also offer corrosion protection to a metal roof against water runoff over the copper pipe.
- Plastic pipe **MUST NOT** be used, as it will not withstand the temperature of the water generated by the solar collectors under stagnation conditions. The solar collectors can generate extremely high water temperatures, up to 150°C, and high water pressure of 1000 kPa. Plastic pipe cannot withstand these temperatures and pressures, and **MUST NOT** be used. Failure of plastic pipe can lead to the release of high temperature water and cause severe water damage and flooding.
- There **must be a continuous fall** in the pipe work between the solar collectors and storage tank. The highest point of the solar cold pipe and solar hot pipe must be where they connect to the solar collectors, to avoid the possibility of air locks occurring in the system.

PIPE LENGTHS

The maximum recommended combined length of the solar cold and solar hot pipes with bends is:

Maximum recommended pipe length and number of 90° bends*						
Pipe Size	1 or 2 Collectors		3 Collectors		4 Collectors	
	Pipe Length	90° Bends	Pipe Length	90° Bends	Pipe Length	90° Bends
DN15	40 metres	20	30 metres	20	NA	NA
DN18	60 metres	20	40 metres	20	32 metres	20

* For each additional 90° bend, reduce the maximum total pipe length by 0.5 metres.

* For each additional metre of pipe length, reduce the number of 90° bends by two.

CONNECTIONS - PLUMBING

RELIEF VALVE

The Temperature and Pressure Relief valve must be fitted before the water heater is operated. Before fitting the relief valve, make sure the probe has not been bent. Seal the thread with Teflon tape - never hemp. Make sure the tape does not hang over the end of the thread.

Screw the valve into the correct opening (refer to the installation diagram on page 23) leaving the valve outlet pointing downwards. Do not use a wrench on the valve body - use the spanner flats provided.

RELIEF VALVE DRAIN

A drain pipe must be fitted to the relief valve to carry the discharge clear of the water heater. Connect the drain line to the relief valve using a disconnection union. The pipe work from the relief valve to the drain should be as short as possible, and fall all the way from the water heater with no restrictions. It should have no more than three right angle bends in it. Use DN15 pipe. The outlet of the drain pipe must be in such a position that flow out of the pipe can be easily seen (refer to AS/NZS 3500.4.2) - but arranged so hot water discharge will not cause injury, damage or nuisance. The relief line must discharge at an outlet or air break not more than 9 metres from the relief valve.

In locations where water pipes are prone to freezing, the drain pipe must be insulated and not exceed 300 mm in length. In this instance, the drain pipe is to discharge into a tundish through an air gap of between 75 mm and 150 mm.

Warning: As the function of the Temperature and Pressure Relief valve on this water heater is to discharge high temperature water under certain conditions, it is strongly recommended the pipe work downstream of the relief valve be capable of carrying water exceeding 93°C. Failure to observe this precaution may result in damage to pipe work and property.

BLEED VALVE DRAIN

A drain pipe must be fitted to the bleed valve to carry the discharge clear of the water heater and solar controls. Connect the drain line to the bleed valve using a disconnection union. The pipe work from the bleed valve to the drain should be as short as possible, and fall all the way from the valve with no restrictions. It should have no more than three right angle bends in it. Use DN15 pipe. The outlet of the drain pipe must be in such a position that flow out of the pipe can be easily seen (refer to AS/NZS 3500.4.2) - but arranged so water discharge will not cause injury, damage or nuisance. The water discharged may be of a high temperature under certain conditions.

CONNECTIONS - PLUMBING

EXPANSION CONTROL VALVE

Local regulations may make it mandatory to install an expansion control valve (ECV) in the cold water supply line. In other areas ECVs are not required unless the saturation index is greater than +0.4 (refer to "Water Supplies" on page 38). However, they may be needed in corrosive water where there are sufficient quantities of silica dissolved in the water. A drain line must be run separately from the drain of the relief valve.

CONNECTIONS - ELECTRICAL

The power supply must not be turned on until the solar storage tank is filled with water, and a satisfactory megger reading is obtained. The solar storage tank with an electric booster heating unit is designed for direct connection to a 240 V AC 50 Hz mains power supply with an isolating switch installed at the switchboard.

Flexible 20 mm conduit is required for the electrical cable to the solar storage tank. The conduit is to be connected to the unit with a 20 mm terminator. Connect the power supply wires directly to the terminal block and earth tab connection, ensuring there are no excess wire loops inside the front cover.

The solar control unit, supplied with a 1.8 metre power cord, requires a 240 V general power outlet (GPO) to be located within 1.2 metres of the installation. The GPO is required to be weatherproof for outdoor installations. If the power supply cord is damaged, it must be replaced in order to avoid a hazard.

ASSEMBLY OF ADJUSTER MECHANISM ON OPTIMA MODELS

When the front cover has been removed, reassemble as follows:

- Remove the knob from the front cover by depressing the locking tabs on the inside of the front cover.
- Turn the thermostat to the lowest temperature (refer to “Temperature Adjustment – Optima” on page 5).
- Fit the front cover.
- Insert the connector shaft through the hole into the thermostat adaptor slots.
- Align the knob slots over the ‘T’ drive on the connector shaft, with the dial at the lowest setting – a firm push with the hand on the knob front face will engage the locking tabs.

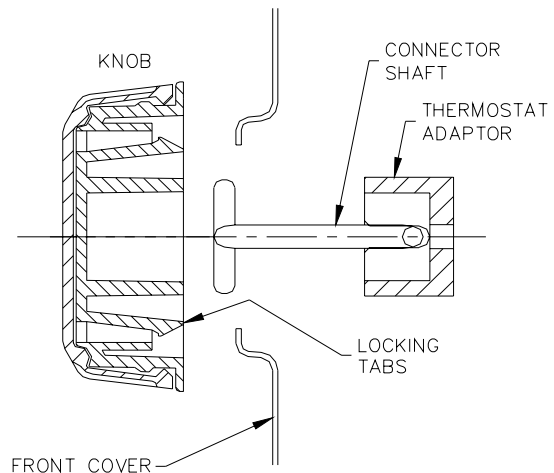

THERMOSTAT SETTING

The water heater thermostat should be set at the lowest temperature that will provide sufficient hot water. Discuss with the user to determine the lowest thermostat setting to ensure sufficient quantities of hot water. Dishwasher running costs can be adversely affected if the thermostat is set below 65°C. The thermostat can be adjusted within the range shown on page 4.

CONNECTIONS - ELECTRICAL

MANUAL CONTROLS

A manual switch can be installed in the power supply circuit to the solar storage tank. The on/off booster switch can be installed with a single element model connected to either a continuous or an Off-Peak electricity supply, or with a twin element model to control the bottom heating unit connected to an Off-Peak electricity supply. The "One Shot Control" switch should only be installed with a single element model connected to a continuous electricity supply. Discuss the power supply and manual switching arrangements with the householder.

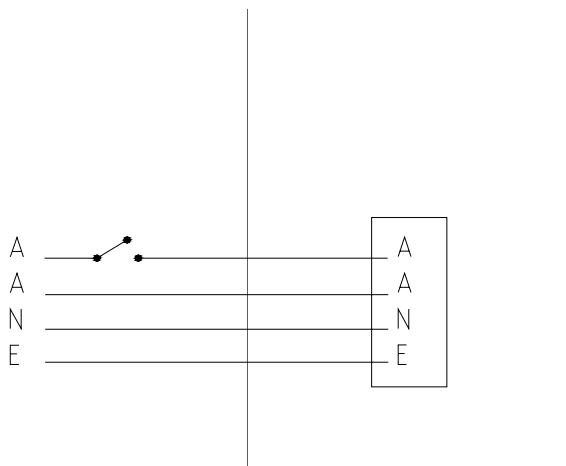

Electrical installation of a twin element model solar storage tank with a manual boosting switch controlling the bottom heating unit

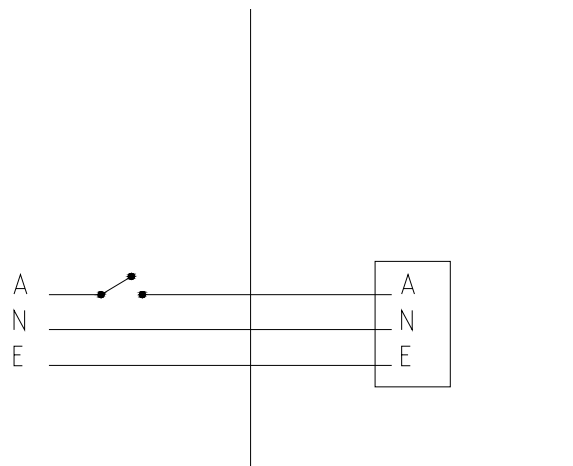

Electrical installation of a single element model solar storage tank with a manual boosting switch

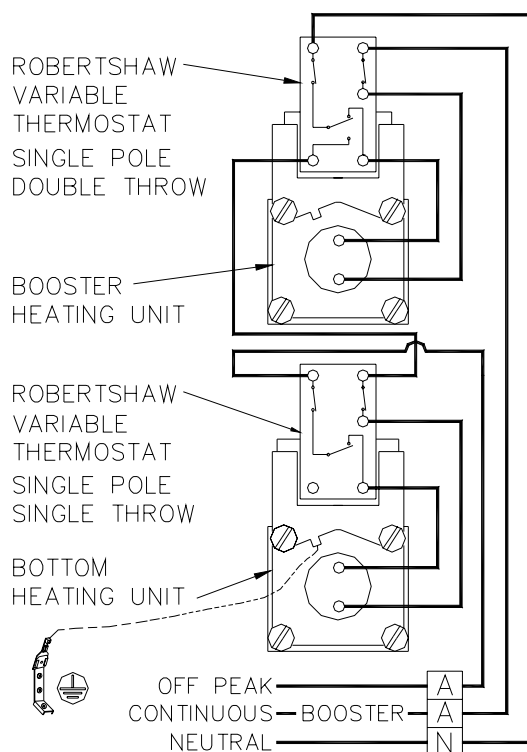

WIRING DIAGRAM FOR TWIN ELEMENT ELECTRIC WATER HEATERS NON-SIMULTANEOUS OPERATION

The active from the continuous electricity supply must be connected to the top heating unit circuit and the active from the Off-Peak electricity supply must be connected to the bottom heating unit circuit for the water heater to operate.

COMMISSIONING

TO FILL AND TURN ON THE WATER HEATER

The power supply to the solar storage tank and solar control unit must not be switched on until the water heater is filled with water and a satisfactory megger reading is obtained.

- Open all of the hot water taps in the house (don't forget the shower). Open the cold water isolation valve fully to the water heater. Air will be forced out of the taps. As water flows freely from each tap, close it. Check the piping for leaks.
- Bleed the solar collectors (refer to "Bleeding the Solar Collectors" on page 34).
- Switch on the electrical supply at the isolating switch to the solar storage tank.
- Plug in the solar control unit and switch the power on.

Explain to the householder the functions and operation of the solar water heater.

BLEEDING THE SOLAR COLLECTORS

Upon completion of the installation, it is necessary to purge the air from the collector circuit. To purge air from the collector circuit:

- Ensure the solar storage tank is full of water and all of the hot taps are turned off.
- Using a flat blade screwdriver, open the bleed valve fitted adjacent to the 5 way tee at the cold water inlet of the water heater (see diagram).
- The mains pressure will force water to flow from the tank and through the pipe work, forcing air from the collector circuit through the bleed valve. This is evidenced by spurting of water from the drain line connected to the bleed valve.

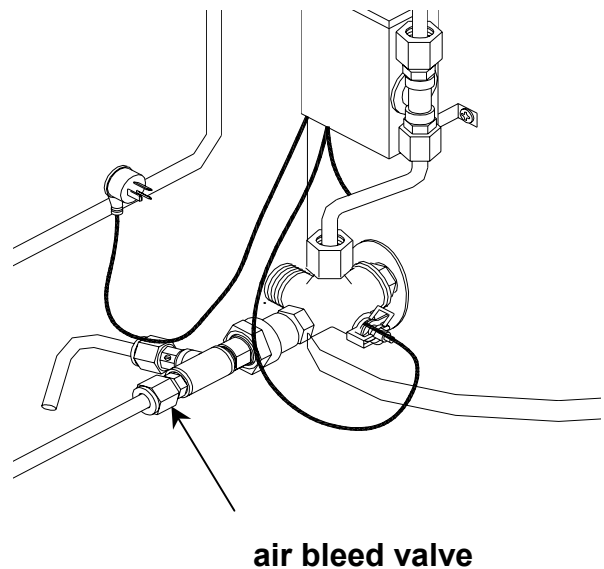

Warning: Exercise caution, as water may be at a very high temperature.

- Close the bleed valve when water runs freely from the drain line.

COMMISSIONING

TO TURN OFF THE WATER HEATER

If it is necessary to turn off the water heater on completion of the installation, such as on a building site or where the premises is vacant, then:

- Close the cold water isolation valve at the inlet to the water heater.
- Switch off the electrical supply at the isolating switch to the solar storage tank and at the power outlet for the solar control unit.

Note: The freeze protection system will be rendered inoperable if electrical power is not available. Damage caused by freezing due to the unavailability of power to the solar control unit is not covered by warranty (refer to “Warranty Exclusions” on page 39). If there is a risk of freezing, then it is necessary to drain the solar collectors and connecting pipe work (refer to “Draining the Solar Collectors” on page 36).

DRAINING THE SOLAR COLLECTORS

To drain the solar collectors and the solar hot and cold pipe:

- Turn off the water heater (refer to “To Turn Off the Water Heater” on page 35).
- Using a flat bladed screw driver, open the bleed valve fitted adjacent to the 5 way tee at the cold water inlet of the water heater (refer to diagram on page 34).
- Undo the compression fitting at the top of the circulator (located at the side of the solar control unit) and disconnect the solar cold pipe. Water will now drain from the solar collectors and the solar hot and cold pipes.
- When water stops flowing from the solar hot and cold pipes, reconnect the solar cold pipe to the circulator and tighten the compression fitting. Close the bleed valve.

DRAINING THE WATER HEATER

- Switch off the electrical supply at the isolating switch to the solar storage tank and at the power outlet for the solar control unit.
- Close the cold water isolation valve at the inlet to the water heater. Close all hot water taps.
- Operate the relief valve release lever - do not let the lever snap back or you will damage the valve seat. Operating the lever will release the pressure in the water heater.
- Undo the union at the cold water inlet to the 5 way tee and attach a hose. Let the other end of the hose go to a drain.
- Operate the relief valve again. This will let air into the water heater, and allow the water to drain through the hose.

WATER SUPPLIES

Your Rheem water heater is manufactured to suit the water conditions of most Australian metropolitan supplies. However, there are some known water supplies which can have detrimental effects on the water heater and its operation and/or life expectancy. If you are unsure of your water quality, you can obtain information from your local water supply authority.

ANODE

By using the correct colour coded anode this water heater can be used in areas where the total dissolved solids (TDS) content in the water is up to 2500 mg/L. In areas where the TDS exceeds 600 mg/L it is possible the black anode, which is the standard anode fitted to the water heater, may be excessively active. To alleviate this, the black anode should be replaced with one colour coded blue. Where the TDS of the water is less than 40 mg/L, such as when the water has been deionised or is from an alpine supply, a high potential anode, colour coded green, should be used. The changing of anodes must be carried out by a plumber or authorised service person.

CAUTION

If your water supply has a TDS greater than 600 mg/L and the anode has not been changed to a blue one, there is the possibility hydrogen gas could accumulate in the top of the water heater during long periods of no use.

If, under these conditions, the water heater has not been used for two or more weeks the following procedure should be carried out before using any electrical appliances (automatic washing machines and dishwashers) which are connected to the hot water supply.

The hydrogen, which is highly flammable, should be vented safely by opening a hot tap and allowing the water to flow. There should be no smoking or naked flame near the tap whilst it is turned on. Any hydrogen gas will be dissipated. This is indicated by an unusual spurting of the water from the tap. Once the water runs freely again, any hydrogen in the system will have been released. In areas where this is likely to occur, the householder should be instructed by the installer on how to dissipate the gas safely.

SATURATION INDEX

The saturation index is used as a measure of the water's corrosive or scaling properties. In a scaling water supply calcium carbonate is deposited out of the water onto any hot metallic surface. When water has a saturation index greater than +0.40 an expansion control valve* must be fitted on the cold water supply after the non-return valve and the solar collectors should be covered when the water heater is not intended to be used for extended periods.

Where the saturation index exceeds 0.80, a water softening device and a low watts density element should be fitted. Where the saturation index is less than -1.0, a corrosion resistant heating unit should be used (contact your nearest Rheem Service Department or Accredited Service Agent).

* Refer to the cold water connection detail on page 21.

WATER HEATERS NOT INSTALLED IN ACCORDANCE WITH THE ABOVE ADVICE WILL NOT BE COVERED BY THE RHEEM WARRANTY.

RHEEM SOLAR WATER HEATER WARRANTY - AUSTRALIA ONLY -

WARRANTY CONDITIONS

1. This warranty is applicable only to water heaters manufactured from 1st August 2002.
2. The water heater must be installed in accordance with the Rheem water heater installation instructions, supplied with the water heater, and in accordance with all relevant statutory and local requirements of the State in which the water heater is installed.
3. Where a failed component or water heater is replaced under warranty, the balance of the original warranty period will remain effective. The replaced part or water heater does not carry a new warranty.
4. Where the water heater is installed outside the boundaries of a metropolitan area as defined by Rheem or further than 25 km from a regional Rheem branch office, or an Accredited Service Agent, the cost of transport, insurance and travelling costs between the nearest Rheem Accredited Service Agent's premises and the installed site shall be the owner's responsibility.
5. The warranty only applies to the water heater and original or genuine (company) component replacement parts and therefore does not cover any plumbing or electrical parts supplied by the installer and not an integral part of the water heater, e.g. pressure limiting valve; isolation valves; non-return valves; electrical switches; pumps or fuse.
6. The water heater must be sized to supply the hot water demand in accordance with the guidelines in the Rheem water heater literature.

WARRANTY EXCLUSIONS

1. REPAIR AND REPLACEMENT WORK WILL BE CARRIED OUT AS SET OUT IN THE RHEEM WATER HEATER WARRANTY, HOWEVER THE FOLLOWING EXCLUSIONS MAY CAUSE THE WATER HEATER WARRANTY TO BECOME VOID AND MAY INCUR A SERVICE CHARGE AND / OR COST OF PARTS.
 - (a) Accidental damage to the water heater or any component, including: Acts of God; failure due to misuse; incorrect installation; attempts to repair the water heater other than by a Rheem Accredited Service Agent or the Rheem Service Department.
 - (b) Where it is found there is nothing wrong with the water heater; where the complaint is related to excessive discharge from the temperature and / or pressure relief valve due to high water pressure; where there is no flow of hot water due to faulty plumbing; where water leaks are related to plumbing and not the water heater or water heater components; where there is a failure of gas, electricity or water supplies; where the supply of gas, electricity or water does not comply with relevant codes or acts.
 - (c) Where the water heater or water heater component has failed directly or indirectly as a result of: excessive water pressure; excessive temperature and / or thermal input; corrosive atmosphere; ice formation in the water ways of a water heater system without a freeze protection system; ice formation in the water ways of a solar Hiline water heater system installed at an altitude more than 600 metres above sea level; ice formation in the water ways of a solar Loline water heater system installed at an altitude more than 800 metres above sea level; ice formation in the water ways of a water heater system with a freeze protection system where the electricity supply has been switched off or has failed; ice formation in the water ways of a solar water heater system where the system has not been installed in accordance with the Rheem water heater installation instructions.
 - (d) Where the water heater is located in a position that does not comply with the Rheem water heater installation instructions or relevant statutory requirements, causing the need for major dismantling or removal of cupboards, doors or walls, or use of special equipment to bring the water heater to floor level or to a serviceable position.
 - (e) Repairs to the water heater due to scale formation in the waterways when the water heater has been connected to a harmful water supply as outlined in the Owner's Guide and Installation Instructions booklet.
 - (f) Breakage of collector glass for any reason including hail damage. (We suggest that the collector glass be covered by your home insurance policy).
2. SUBJECT TO ANY STATUTORY PROVISIONS TO THE CONTRARY, THIS WARRANTY EXCLUDES ANY AND ALL CLAIMS FOR DAMAGE TO FURNITURE, CARPETS, WALLS, FOUNDATIONS OR ANY OTHER CONSEQUENTIAL LOSS EITHER DIRECTLY OR INDIRECTLY DUE TO LEAKAGE FROM THE WATER HEATER, OR DUE TO LEAKAGE FROM FITTINGS AND / OR PIPE WORK OF METAL, PLASTIC OR OTHER MATERIALS CAUSED BY WATER TEMPERATURE, WORKMANSHIP OR OTHER MODES OF FAILURE.

RHEEM SOLAR WATER HEATER WARRANTY - AUSTRALIA ONLY -

Rheem will:

- a) Repair or, if necessary replace any Rheem water heater; or
- b) Replace any component (or, if necessary, arrange the installation of a new water heater), which falls within the Warranty Periods specified below, in accordance with and subject to the following table, conditions and exclusions.

Installation	Model	Period	Warranty
--------------	-------	--------	----------

All Components (from date of installation)

All installations	All models	Year 1	New component, solar collector or water heater (at Rheem's sole discretion) free of charge, including labour**
-------------------	------------	--------	--

Cylinder (from date of installation)

Water heater installed in a "single-family domestic dwelling with a thermostat setting below 76°C"	Rheemglas Hiline Loline	Years 2 & 3	New water heater, free of charge, including labour**
		Years 4 & 5	New water heater free of charge, with installation and labour costs being the responsibility of the owner.
	Optima Heavy Duty	Years 2 to 5	New water heater, free of charge, including labour**
		Years 6 to 10	New water heater free of charge, with installation and labour costs being the responsibility of the owner.
Water heater installed in any other than a "single-family domestic dwelling with a thermostat setting below 76°C"	Rheemglas Hiline Loline	Years 2 & 3	New water heater free of charge, with installation and labour costs being the responsibility of the owner.
	Optima Heavy Duty	Years 2 to 5	New water heater free of charge, with installation and labour costs being the responsibility of the owner.

Solar Collector (from date of installation)

All installations	SCT200	Years 2 to 5	New solar collector, free of charge with installation and labour costs being the responsibility of the owner.
-------------------	--------	-----------------	---

Notes:

** Refer to item 4 of warranty conditions.

Rheem reserves the right to transfer fully functional components from the defective water heater to the replacement water heater if required. The term "water heater" used in this Warranty and the Warranty Conditions and Exclusions means the Rheem supplied; solar storage tank(s), solar collector(s), components and kit(s).

In addition to this warranty, the Trade Practices Act 1974 and similar laws in each state and territory provide the owner under certain circumstances with certain minimum statutory rights in relation to your Rheem water heater. This warranty must be read subject to that legislation and nothing in this warranty has the effect of excluding, restricting or modifying those rights.

<p>RHEEM AUSTRALIA PTY LTD A.B.N 21 098 823 511</p>	<p>FOR SERVICE TELEPHONE 131 031 AUSTRALIA 0800 657 335 NEW ZEALAND or refer local Yellow Pages</p>
--	---

Note: Every care has been taken to ensure accuracy in preparation of this publication. No liability can be accepted for any consequences, which may arise as a result of its application. 129872D